

ini[®] NINGBO DAGANG INI
HYDRAULIC CO.,LTD.



>>> [Http: //www.china-ini.com](http://www.china-ini.com)

2010 Catalogue

Product Shows & Applications

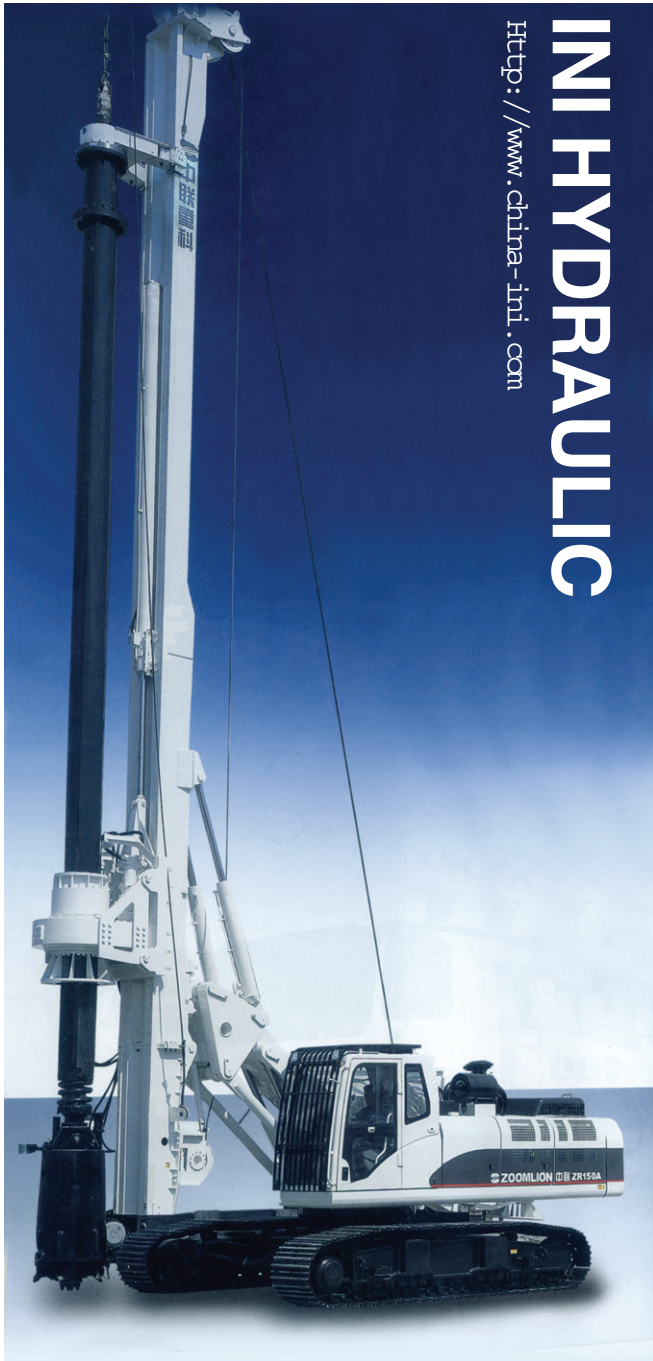

INI HYDRAULIC
[Http://www.china-ini.com](http://www.china-ini.com)

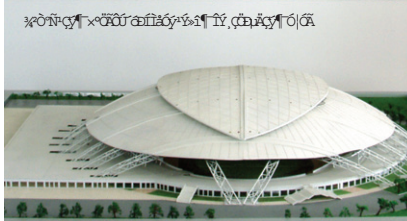
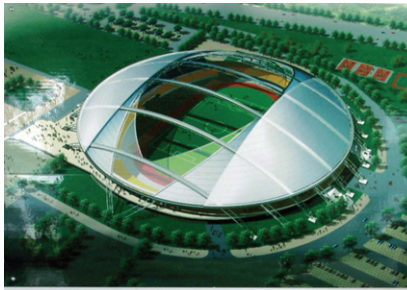

Product Shows & Applications

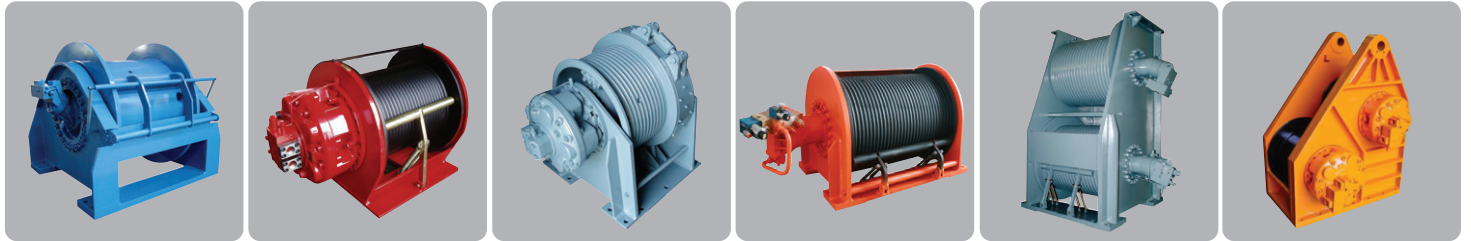

INI HYDRAULIC
[Http://www.china-ini.com](http://www.china-ini.com)

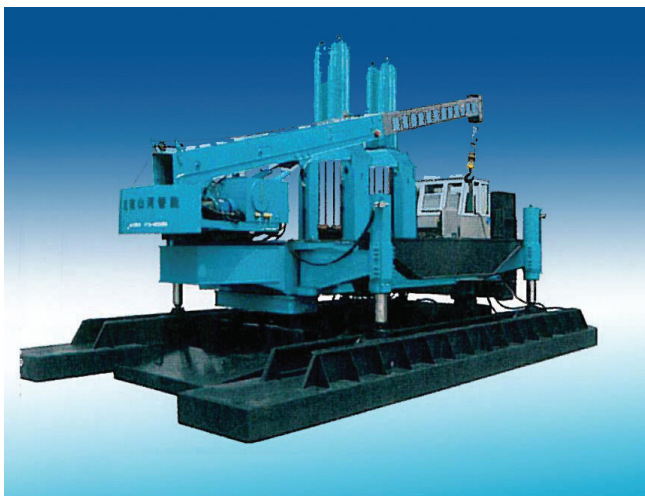



Brief Introduction



NINGBO DAGANG INI HYDRAULIC CO., LTD is situated in a state-level economic and technological development zone of BEILUN district, NINGBO. The factory covers almost 40,000 m², with 38,000 m² building area. The registered capital is 6,500,000 USD, and the total investment is 15,000,000 USD. Currently, the company is staffed with 400 employees, 20% among whom are professional technicians. The company has a strong R&D team, led by the general manager—a professorate senior engineer, who takes special allowance from State Council. The team also includes one doctor, two masters, senior engineers, engineers and engineer trainees, and two retired German experts from ZF GROUP as honor employees. They will come to the factory to help and give advices once a year. Up to now, the company owns eight invention patents and thirty practical innovation and figure patents. Several other patents are under reviewing. The company is specialized in manufacturing of electro-hydraulic proportional valves, hydraulic motors, hydrostatic drives, hydraulic winches, planetary gearboxes, high accuracy rotary flow dividers and the whole set of hydraulic system. These patent products are widely used in engineering machinery, petroleum, mining industry, geological exploration, ships, metallurgy, light industry, agriculture, landscape, environment and military industry. Now we are stepping into the international market, and our products are being exported to Southeast Asia, Middle East, Germany, USA, Netherlands, Turkey, India, Russia, Korea and other countries and regions around the world.

The company has more than 150 advanced manufacturing equipment, half of which were imported. 60% of all the machines are CNC, including three-dimension coordinate measuring machine, universal gear measuring machine, digital ultrasonic inspection machine, and universal tool microscope. A static hydrostatic drives lab and 12 factory test stands were established for product testing. The company passed ISO 9001 quality system certification, CCS certification and CE certification. The annual sales volume reaches 250 million RMB, with a production capacity of over 300 million RMB. The company was appraised as a state-level high-tech enterprise and is a patent pioneer enterprise.

IWYHG high speed hydraulic slewing drives series

1. brief introduction :

IWYHG high speed hydraulic slewing drives series are designed for excavators. It consists of valve block with brake function, hydraulic motor, brake, multi-stage planetary gearbox. It features high working pressure, good stability, compact design, light weight, easy installation and maintenance. It can bear hydraulic and external load impact. The output gear shaft can directly drive the ring gear on the slewing platform. With above advantages, these products are widely used in slewing platform drives in construction vehicles, crawler excavators, aerial platforms, tracked vehicles and so on. They are not only popular in Chinese market, but also exported to Singapore, India, Korea, Netherlands and other countries in the world.

The models listed in this catalogue are already put into production. We can also produce different products according to different installation dimension and reduction ratio requested by customers. Please contact our technical department or sales department for more information if need.

2. Model selection:

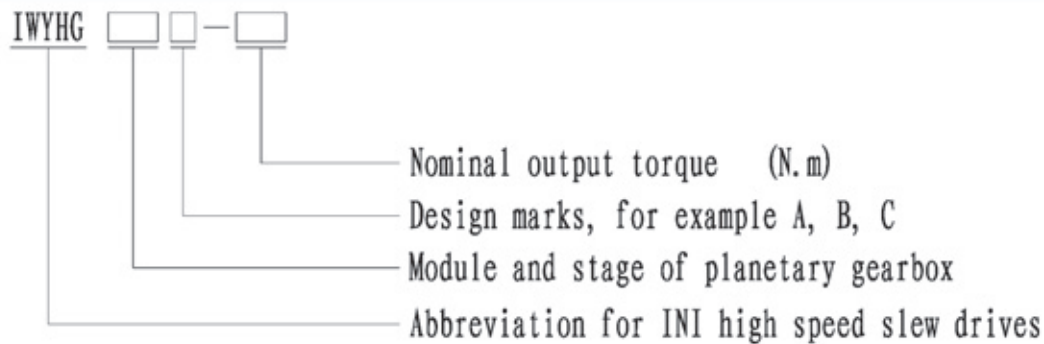

3. Example of model no:

IWYHG 33A -2800 means the slewing drive has two-stage planetary gearboxes, module of first stage gearbox is 3mm, module of second stage gearbox is 3mm, the design mark is A, and the nominal output torque is 2800N.m.

4. Definition

- 1) Total displacement (ml/r) is the amount of oil needed for one rotation of hydraulic transmission drive.
 Total displacement (ml/r) = displacement of hydraulic motor (ml/r) * reduction ratio
- 2) Theoretical oil flow of the pump (l/min) = total displacement (ml/r) * output shaft speed of hydraulic transmission drive (r/min) / 1000

Dimension

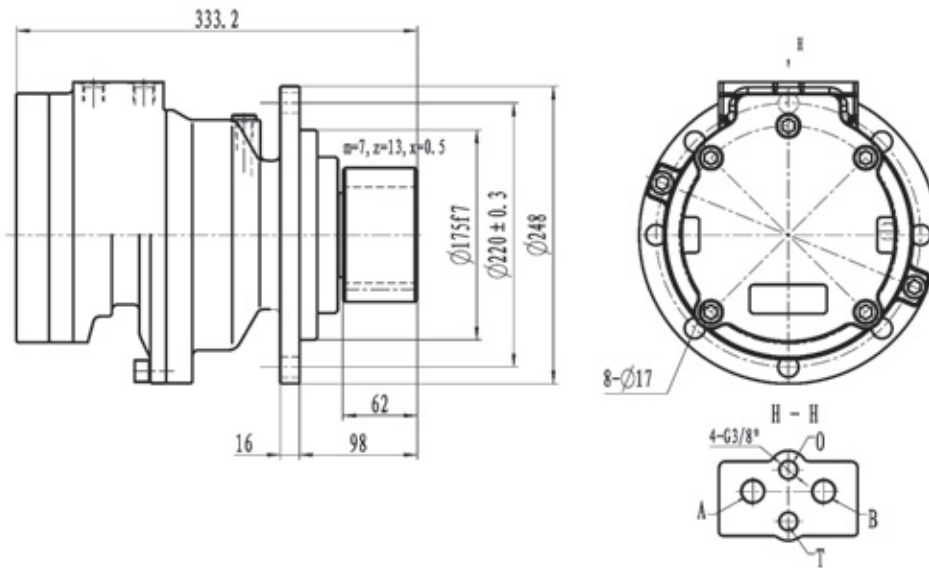

Technical Data

Output Torque (N · m)	Speed (r/min)	Ratio	Rated Pressure (MPa)	Displacement (ml/r)	Motor Displacement (ml/r)	Weight (Kg)	Excavator type (Ton)
1600	0-90	19.46	25	701.436	36.045	50	6

Hydraulic diagram

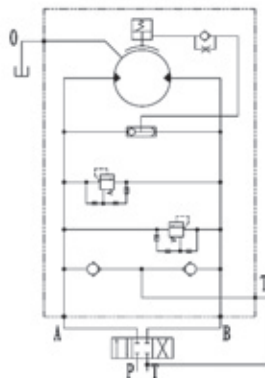

1. The neutral position of the control valve must be "0" type.
2. The oil boost port T of hydraulic motor should be connected with T port of control valve.
3. Maximum pressure of the brake is 5MPa.

Dimension

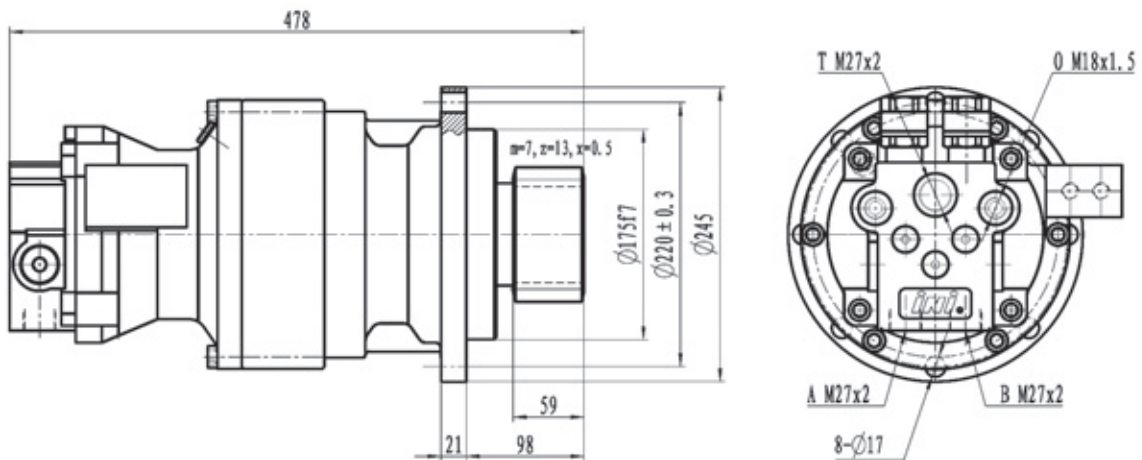

Technical Data

Output Torque (N · m)	Speed (r/min)	Ratio	Rated Pressure (MPa)	Displacement (ml/r)	Motor Displacement (ml/r)	Weight (Kg)	Excavator type (Ton)
2150	0-90	19.46	25	701.436	36.045	70	6

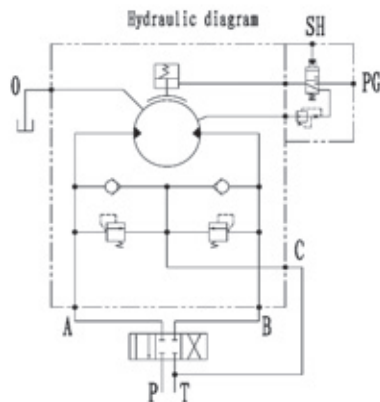

1. The neutral position of the control valve must be "0" type.
2. The oil boost port T of hydraulic motor should be connected with T port of control valve.
3. Maximum pressure of the brake is 5MPa.

Dimension

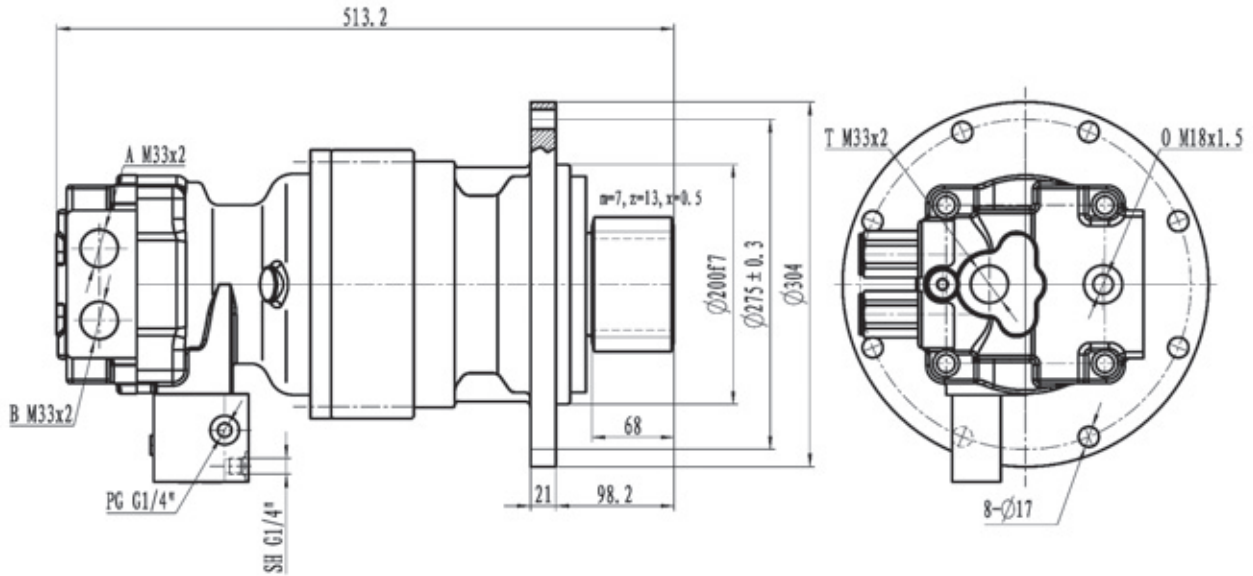

Technical Data

Output Torque (N · m)	Speed (r/min)	Ratio	Rated Pressure (MPa)	Displacement (ml/r)	Motor Displacement (ml/r)	Weight (Kg)	Excavator type (Ton)
2600	0-80	19.46	20	1028.87	52.871	70	7-8

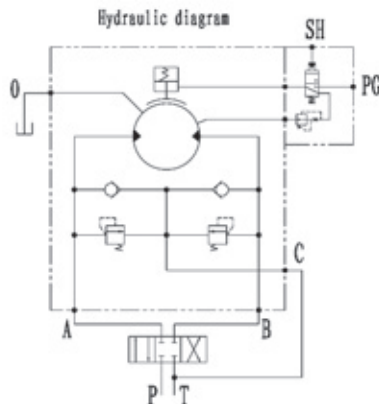

1. The neutral position of the control valve must be "0" type.
2. The oil boost port T of hydraulic motor should be connected with T port of control valve.
3. Maximum pressure of the brake is 5MPa.

Dimension

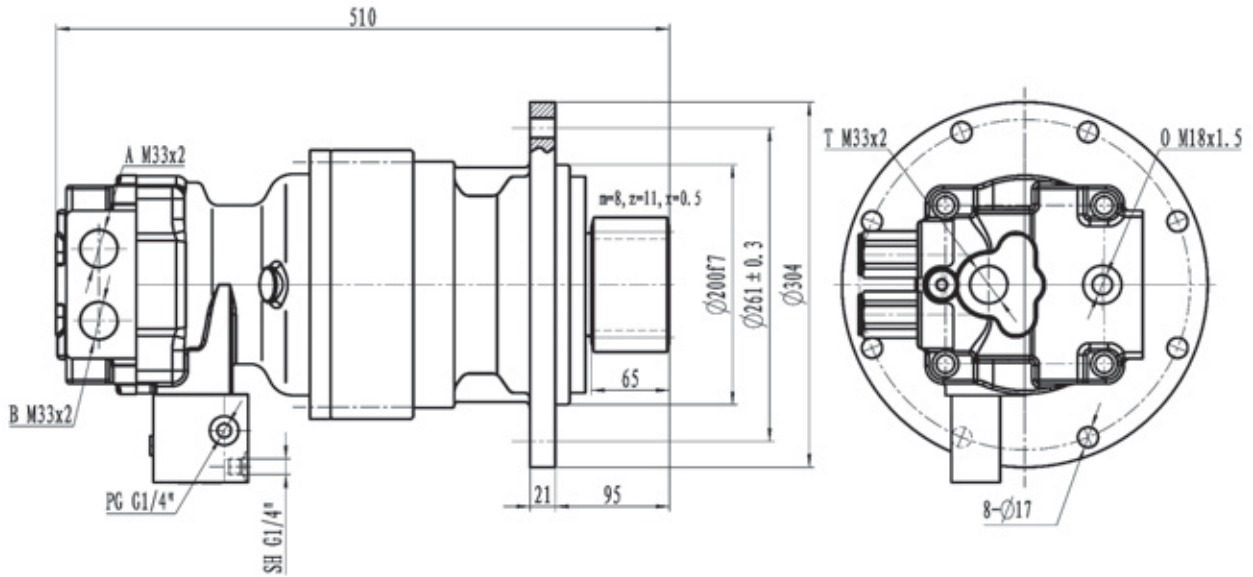

Technical Data

Output Torque (N · m)	Speed (r/min)	Ratio	Rated Pressure (MPa)	Displacement (ml/r)	Motor Displacement (ml/r)	Weight (Kg)	Excavator type (Ton)
2600	0-80	19.46	20	1028.87	52.871	70	8

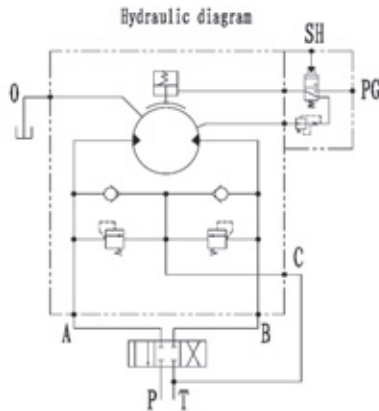

1. The neutral position of the control valve must be "0" type.
2. The oil boost port T of hydraulic motor should be connected with T port of control valve.
3. Maximum pressure of the brake is 5MPa.

Dimension

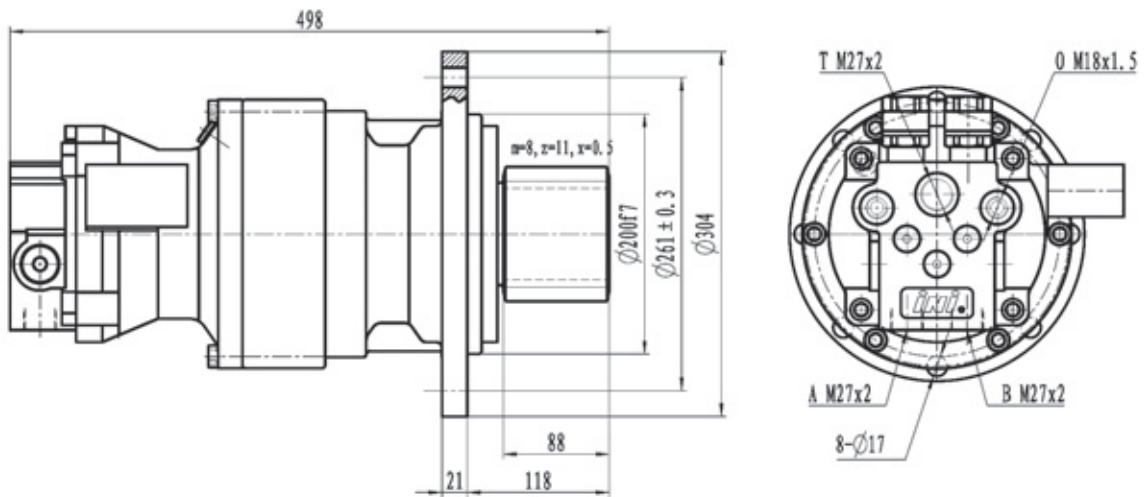

Technical Data

Output Torque (N · m)	Speed (r/min)	Ratio	Rated Pressure (MPa)	Displacement (ml/r)	Motor Displacement (ml/r)	Weight (Kg)	Excavator type (Ton)
1900	0-102	19.46	22	701.436	36.045	70	7.5T

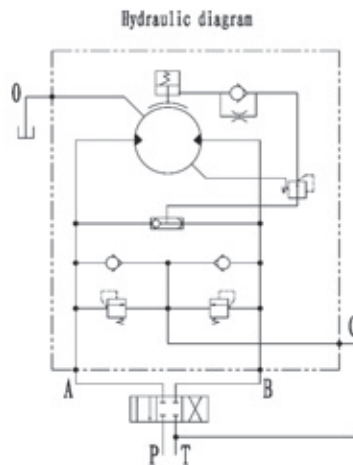

1. The neutral position of the control valve must be "0" type.
2. The oil boost port T of hydraulic motor should be connected with T port of control valve.
3. Maximum pressure of the brake is 5MPa.

Dimension

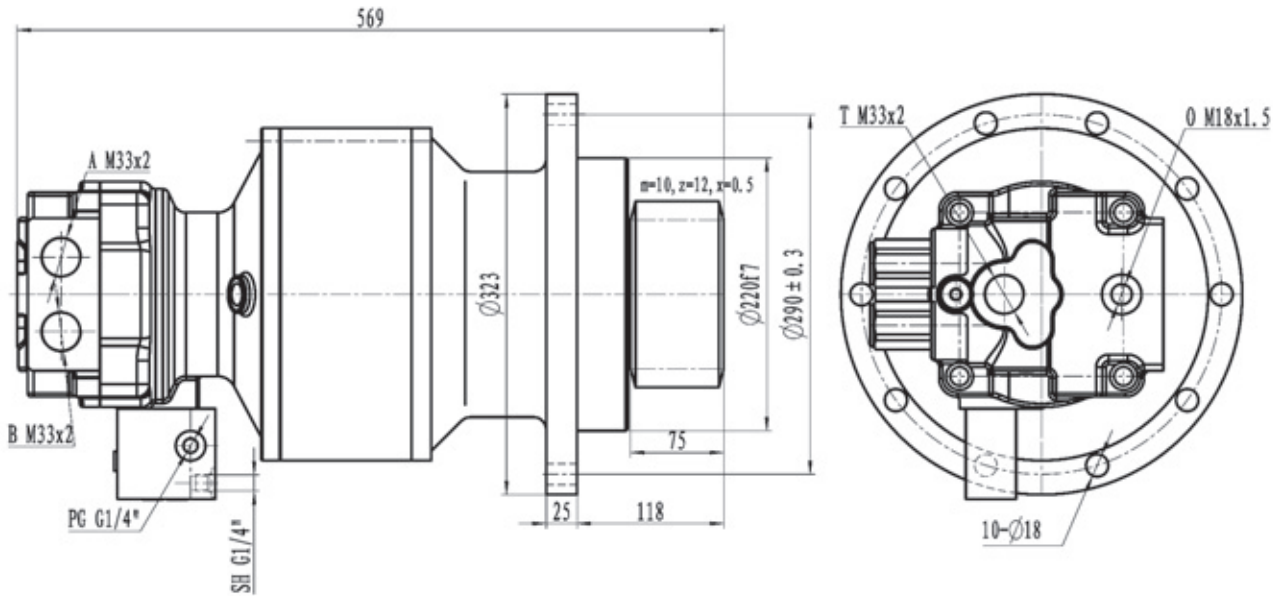

Technical Data

Output Torque (N · m)	Speed (r/min)	Ratio	Rated Pressure (MPa)	Displacement (ml/r)	Motor Displacement (ml/r)	Weight (Kg)	Excavator type (Ton)
3500	0-80	18.4	23	1192.9	64.832	90	12-14

Hydraulic diagram

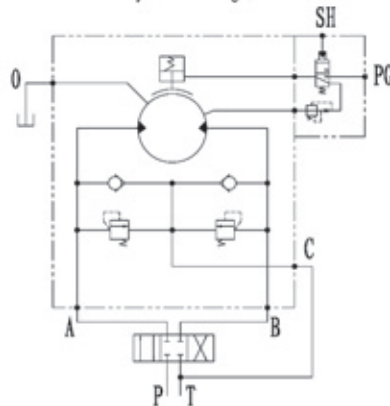

1. The neutral position of the control valve must be "0" type.
2. The oil boost port T of hydraulic motor should be connected with T port of control valve.
3. Maximum pressure of the brake is 5MPa.

Dimension

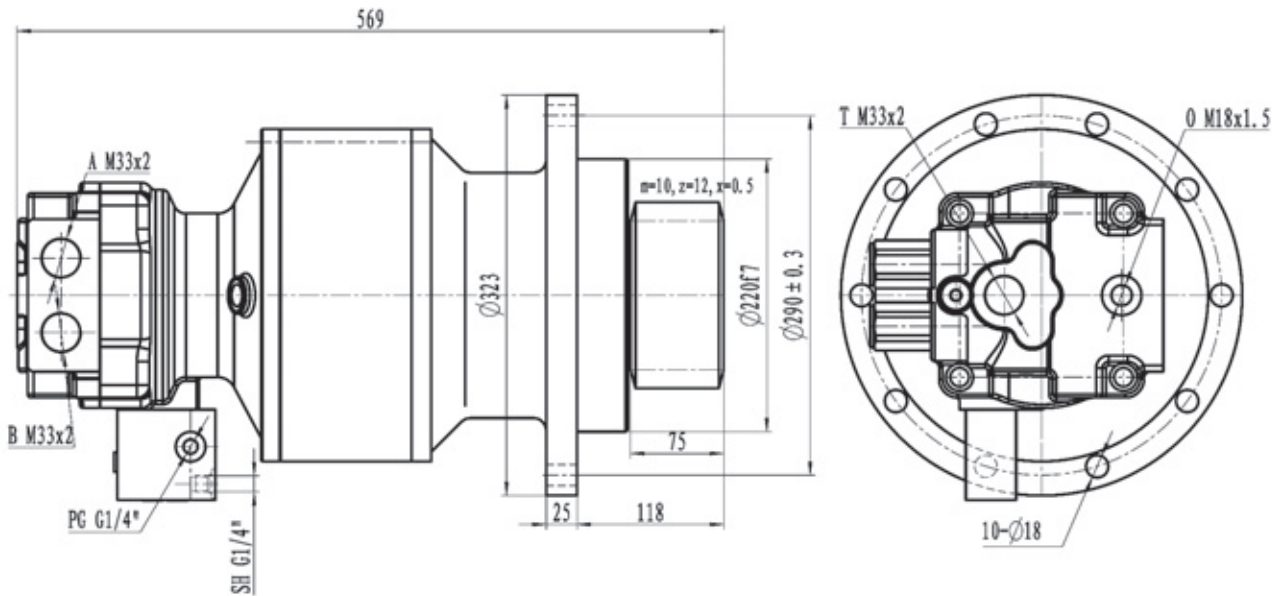

Technical Data

Output Torque (N · m)	Speed (r/min)	Ratio	Rated Pressure (MPa)	Displacement (ml/r)	Motor Displacement (ml/r)	Weight (Kg)	Excavator type (Ton)
4000	0-100	18.4	26	1192.9	64.832	90	14-16

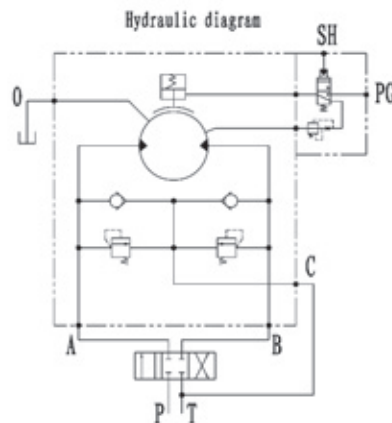

1. The neutral position of the control valve must be "0" type.
2. The oil boost port T of hydraulic motor should be connected with T port of control valve.
3. Maximum pressure of the brake is 5MPa.

Dimension

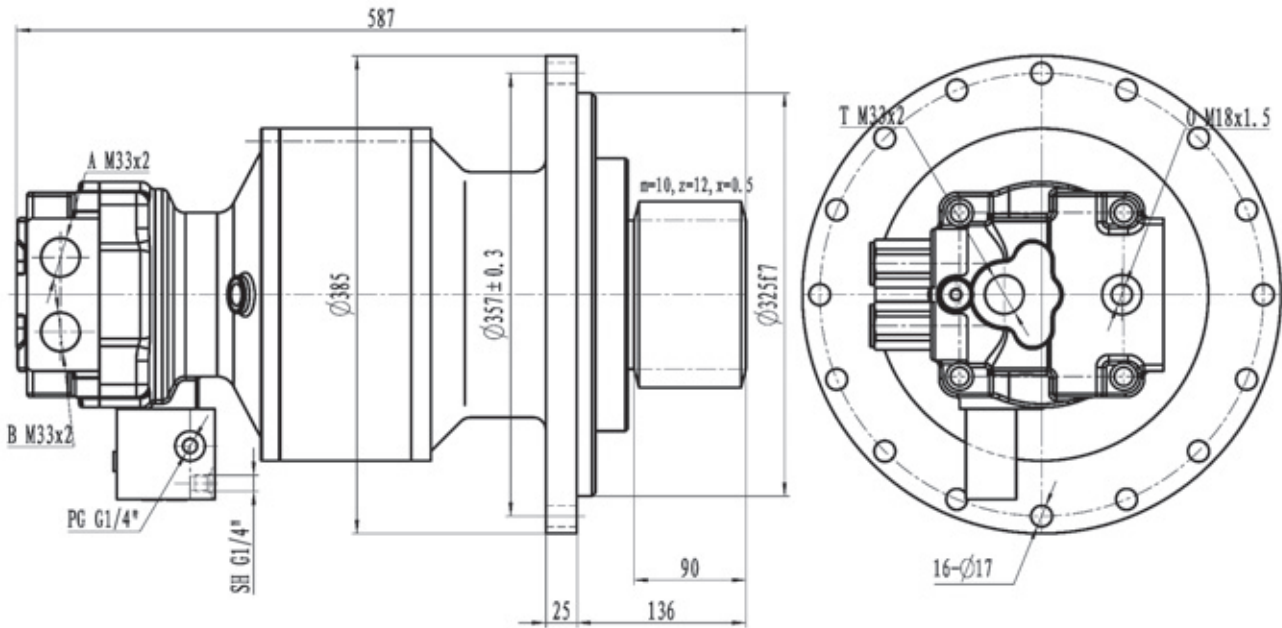

Technical Data

Output Torque (N · m)	Speed (r/min)	Ratio	Rated Pressure (MPa)	Displacement (ml/r)	Motor Displacement (ml/r)	Weight (Kg)	Excavator type (Ton)
4000	0-100	18.4	26	1192.9	64.832	90	14-16

Hydraulic diagram

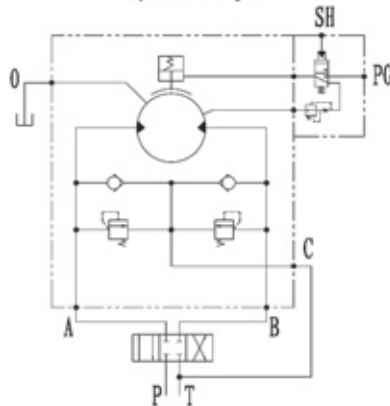

1. The neutral position of the control valve must be "0" type.
2. The oil boost port T of hydraulic motor should be connected with T port of control valve.
3. Maximum pressure of the brake is 5MPa.

Dimension

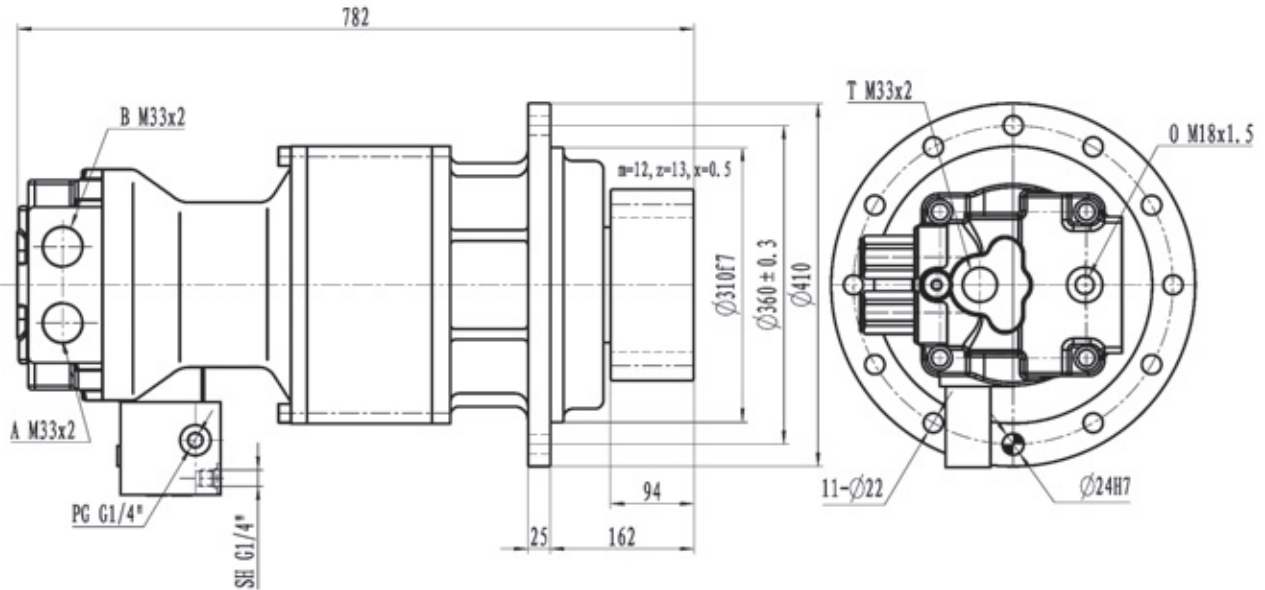

Technical Data

Output Torque (N · m)	Speed (r/min)	Ratio	Rated Pressure (MPa)	Displacement (ml/r)	Motor Displacement (ml/r)	Weight (Kg)	Excavator type (Ton)
9000	0-64	26.6	24	3063.23	115.12	125	19-20

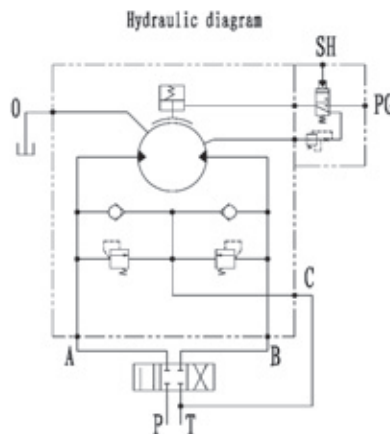

1. The neutral position of the control valve must be "0" type.
2. The oil boost port T of hydraulic motor should be connected with T port of control valve.
3. Maximum pressure of the brake is 5MPa.